

# MDF-E+

## ELEKTRİKLİ DÖNER FIRIN ELECTIC ROTARY OVEN



**HAZIRLANIYOR**  
*PREPARING*

**HAZIR**  
*READY*

**ARIZA**  
*FAILURE*



**Malzemelerinizi koyabileceğiniz  
manyetik alan**  
*Magnetic Field to Hold Your  
Supplies*

**3 cm RAMPA**  
*yüksekliği*  
**3 cm Ramp**  
*Height*





## MUADİL MAKİNALARA GÖRE %30 ELEKTRİK TASARRUFU

30% ELECTRICITY  
SAVINGS COMPARED  
TO EQUIVALENT  
MACHINES



TEKNİK RESİM / TECHNICAL DRAWING

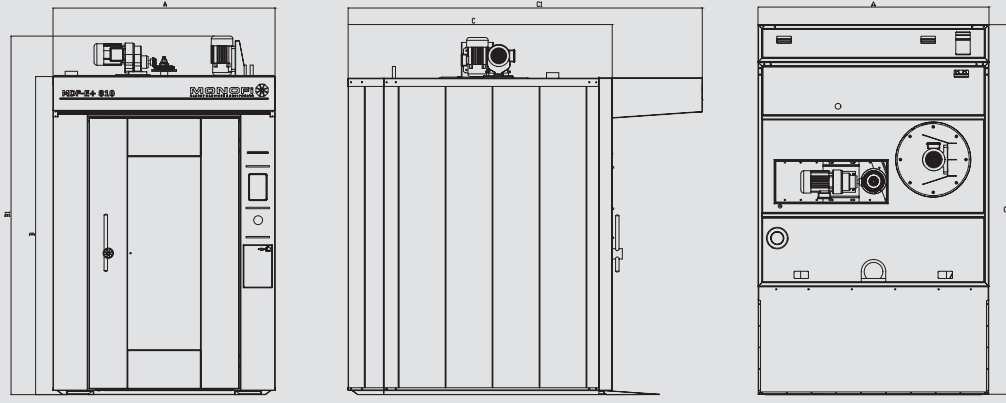

| MODEL/MODEL                                        | BİRİM<br>UNIT          | MDF-E+ 570         | MDF-E+ 680 | MDF-E+ 680L | MDF-E+ 810                     | MDF-E+ 680x2          |
|----------------------------------------------------|------------------------|--------------------|------------|-------------|--------------------------------|-----------------------|
| KAPASİTE (8 SAAT/HAMUR)<br>CAPACITY (8 HOUR/DOUGH) | KG                     | 700                | 1000       | 1200        | 2150                           | 2400                  |
| PİŞİRME ALANI / BAKING SURFACE                     | m <sup>2</sup>         | 4,2                | 5,2 - 7,2  | 6,6 - 8,5   | 11,2 - 14,4                    | 19,2                  |
| TEPSİ SAYISI / NUMBER OF TRAYS                     | ADET                   | 9-12               | 11 - 15    | 14 - 18     | 14 - 18                        | 32                    |
| TEPSİ EBATI / TRAY SIZE                            | mm                     | 530x650<br>500x700 | 600x800    | 600x800     | 750x1040 - 740x980<br>800x1000 | 600*800x2<br>800x1200 |
| TAVALAR ARASI MESAFE<br>DISTANCE BETWEEN TRAYS     | mm                     | 114-85             | 114 - 90   | 114 - 90    | 114 - 90                       | 114 - 90              |
| GENİŞLİK (W) / WIDTH (W)                           | mm                     | 1150               | 1300       | 1300        | 1600                           | 1900                  |
| UZUNLUK (L) / LENGTH (L)                           | mm                     | 1350               | 1600       | 1600        | 2000                           | 2250                  |
| YÜKSEKLİK (H) / HEIGHT (H)                         | mm                     | 1750               | 2000       | 2250        | 2250                           | 2250                  |
| ELEKTRİK GÜCÜ / ELECTRICAL POWER                   | KW                     | 3                  | 3,5        | 3,5         | 3,5                            | 5,5                   |
| ISI KAPASİTESİ / HEATING CAPACITY                  | kcal/saat              | 32000              | 50000      | 60000       | 70000                          | 95000                 |
| ENERJİ KAYNAKLARI / SOURCE OF ENERGY               | Elektrik Enerjisi      |                    |            |             |                                |                       |
| FİRİN AĞIRLIĞI / WEIGHT OF OVEN                    | KG                     | 900                | 1150       | 1300        | 1600                           | 2150                  |
| KONTROL SİSTEMİ / CONTROL SYSTEM                   | Manuel - Dijital - PLC |                    |            |             |                                |                       |
| YAKIT TÜKETİMİ / CONSUMPTION OF FUEL               | KW                     | 25                 | 35         | 45          | 55                             | 85                    |

\*Kapasite mamulün gramajına ve pişirme süresine göre değişkenlik gösterebilir. The capacity shall variable according to the weight and baking time of the product

\*\*Normal şartlar altındaki yakıt tüketim değeri. Energy COOSlrption under normal conditions

\*\*\*İmalatçı firma haber vermeksizin değişiklik yapma hakkını saklı tutar. Manufacturer reserve the right to change specifications without prior notice ..